

# Area of Trapezium Worksheet

## Question 1

The area of a trapezium is  $96 \text{ cm}^2$ . One parallel side is  $28 \text{ cm}$  and height is  $6 \text{ cm}$ . Find the other parallel side.

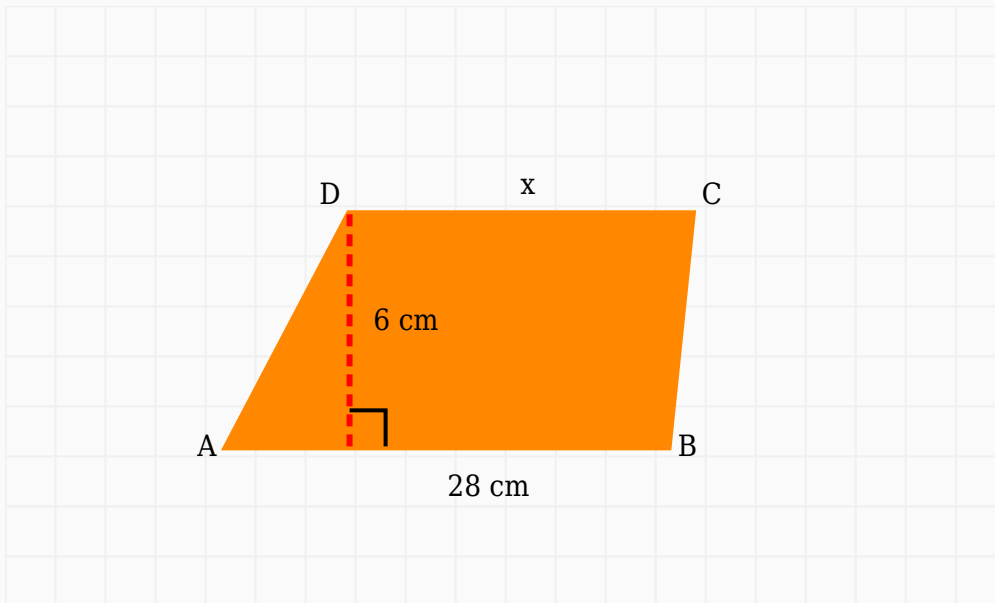

**Solution:**

**Formula:**  $\text{Area} = \text{Height} \times (\text{a} + \text{b}) \div 2$

$$96 = 6 \times (x + 28) \div 2$$

$$192 = 6 \times (x + 28)$$

$$32 = x + 28$$

$$x = 4 \text{ cm}$$

**Answer:**  $4 \text{ cm}$

## Question 2

The area of a trapezium is  $286 \text{ cm}^2$ . One parallel side is  $30 \text{ cm}$  and height is  $13 \text{ cm}$ . Find the other parallel side.

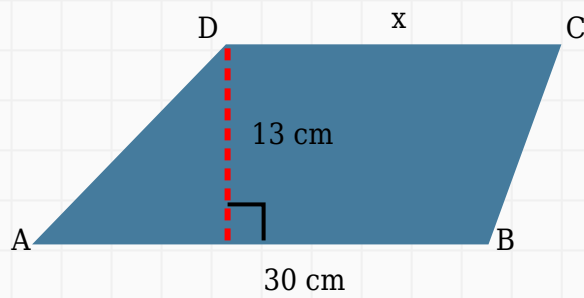

**Solution:**

**Formula: Area = Height  $\times$  (a + b)  $\div$  2**

$$286 = 13 \times (x + 30) \div 2$$

$$572 = 13 \times (x + 30)$$

$$44 = x + 30$$

$$x = 14 \text{ cm}$$

**Answer:** 14 cm

### Question 3

Find the area of the trapezium having parallel sides 13 m and 25 m with height 5 m.

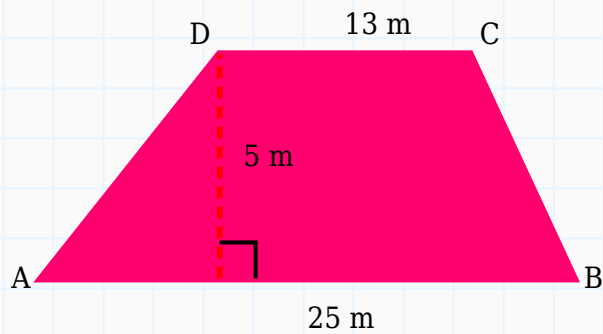

**Solution:**

**Formula:**  $\text{Area} = \text{Height} \times (\text{Sum of parallel sides}) \div 2$

$$\text{Area} = 5 \times (13 + 25) \div 2$$

$$\text{Area} = 5 \times 38 \div 2$$

$$\text{Area} = 95 \text{ m}^2$$

**Answer:**  $95 \text{ m}^2$

#### Question 4

The area of a trapezium is  $157.5 \text{ m}^2$ . One parallel side is 17 m and height is 15 m. Find the other parallel side.

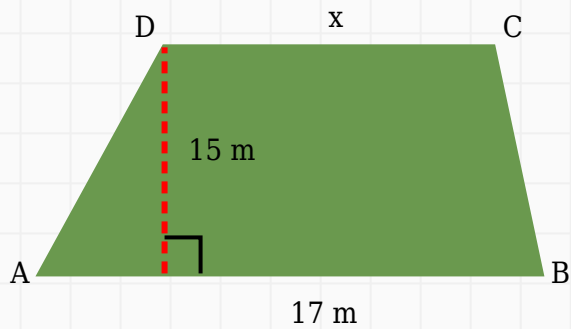

**Solution:**

**Formula: Area = Height  $\times$  (a + b)  $\div$  2**

$$157.5 = 15 \times (x + 17) \div 2$$

$$315 = 15 \times (x + 17)$$

$$21 = x + 17$$

$$x = 4 \text{ m}$$

**Answer:** 4 m

### Question 5

The area of a trapezium is  $192 \text{ m}^2$ . Its parallel sides are 10 m and 22 m. Find the height.



**Solution:**

**Formula: Height =  $(2 \times \text{Area}) \div \text{Sum of parallel sides}$**

$$\text{Height} = (2 \times 192) \div (10 + 22)$$

$$\text{Height} = 384 \div 32$$

$$\text{Height} = 12 \text{ m}$$

**Answer:** 12 m

### Question 6

The area of a trapezium is  $96 \text{ cm}^2$ . One parallel side is 23 cm and height is 6 cm. Find the other parallel side.

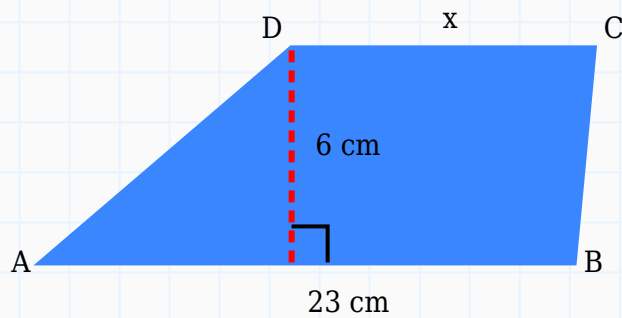

**Solution:**

**Formula: Area = Height  $\times$  (a + b)  $\div$  2**

$$96 = 6 \times (x + 23) \div 2$$

$$192 = 6 \times (x + 23)$$

$$32 = x + 23$$

$$x = 9 \text{ cm}$$

**Answer:** 9 cm

### Question 7

The area of a trapezium is 135 m<sup>2</sup>. Its parallel sides are 13 m and 17 m. Find the height.

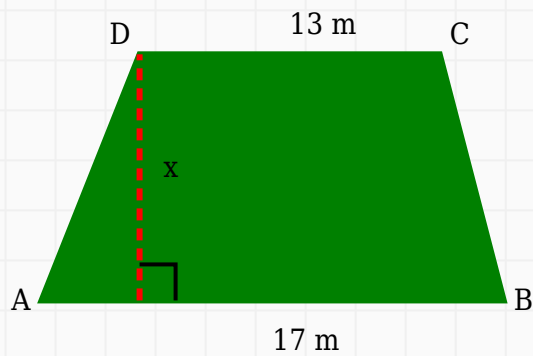

**Solution:**

**Formula: Height =  $(2 \times \text{Area}) \div \text{Sum of parallel sides}$**

$$\text{Height} = (2 \times 135) \div (13 + 17)$$

$$\text{Height} = 270 \div 30$$

$$\text{Height} = 9 \text{ m}$$

**Answer:** 9 m

### Question 8

The area of a trapezium is  $130 \text{ cm}^2$ . Its parallel sides are 10 cm and 16 cm. Find the height.

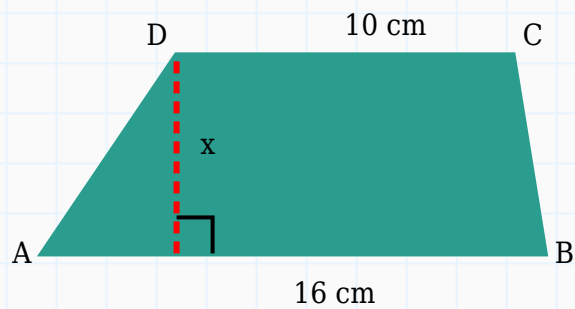

**Solution:**

**Formula: Height =  $(2 \times \text{Area}) \div \text{Sum of parallel sides}$**

$$\text{Height} = (2 \times 130) \div (10 + 16)$$

$$\text{Height} = 260 \div 26$$

$$\text{Height} = 10 \text{ cm}$$

**Answer:** 10 cm

### Question 9

Find the area of the trapezium having parallel sides 8 m and 22 m with height 11 m.

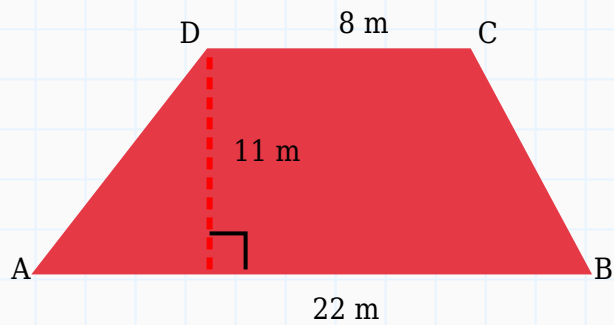

**Solution:**

**Formula:**  $\text{Area} = \text{Height} \times (\text{Sum of parallel sides}) \div 2$

$$\text{Area} = 11 \times (8 + 22) \div 2$$

$$\text{Area} = 11 \times 30 \div 2$$

$$\text{Area} = 165 \text{ m}^2$$

**Answer:**  $165 \text{ m}^2$

### Question 10

The area of a trapezium is  $112 \text{ m}^2$ . Its parallel sides are 4 m and 24 m. Find the height.

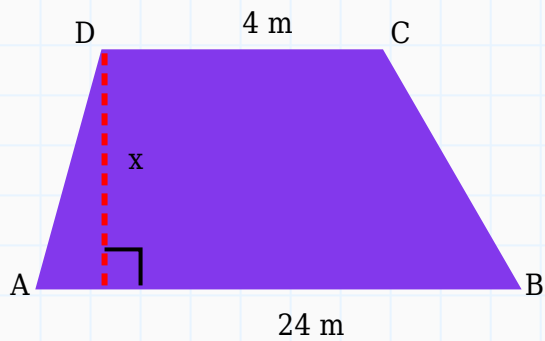

**Solution:**

**Formula: Height = (2 × Area) ÷ Sum of parallel sides**

$$\text{Height} = (2 \times 112) \div (4 + 24)$$

$$\text{Height} = 224 \div 28$$

$$\text{Height} = 8 \text{ m}$$

**Answer:** 8 m

### Question 11

Find the area of the trapezium having parallel sides 12 m and 27 m with height 13 m.

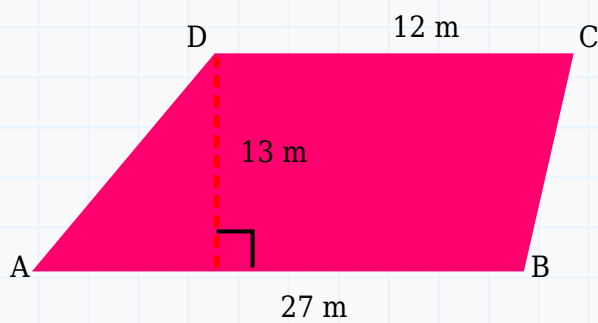

**Solution:**

**Formula:**  $\text{Area} = \text{Height} \times (\text{Sum of parallel sides}) \div 2$

$$\text{Area} = 13 \times (12 + 27) \div 2$$

$$\text{Area} = 13 \times 39 \div 2$$

$$\text{Area} = 253.5 \text{ m}^2$$

**Answer:**  $253.5 \text{ m}^2$

### Question 12

The area of a trapezium is  $156 \text{ m}^2$ . One parallel side is  $17 \text{ m}$  and height is  $12 \text{ m}$ . Find the other parallel side.

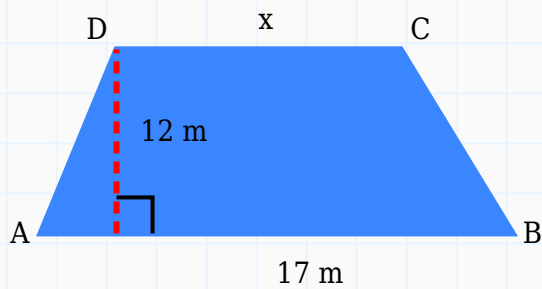

**Solution:**

**Formula: Area = Height  $\times$  (a + b)  $\div$  2**

$$156 = 12 \times (x + 17) \div 2$$

$$312 = 12 \times (x + 17)$$

$$26 = x + 17$$

$$x = 9 \text{ m}$$

**Answer:** 9 m

### Question 13

The area of a trapezium is  $144 \text{ cm}^2$ . Its parallel sides are 4 cm and 28 cm. Find the height.

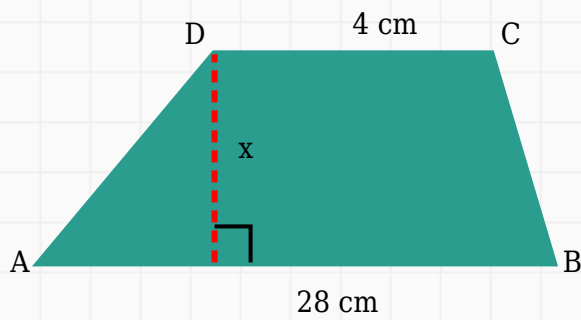

**Solution:**

**Formula: Height =  $(2 \times \text{Area}) \div \text{Sum of parallel sides}$**

$$\text{Height} = (2 \times 144) \div (4 + 28)$$

$$\text{Height} = 288 \div 32$$

$$\text{Height} = 9 \text{ cm}$$

**Answer:** 9 cm

### Question 14

The area of a trapezium is  $112 \text{ cm}^2$ . Its parallel sides are 9 cm and 19 cm. Find the height.

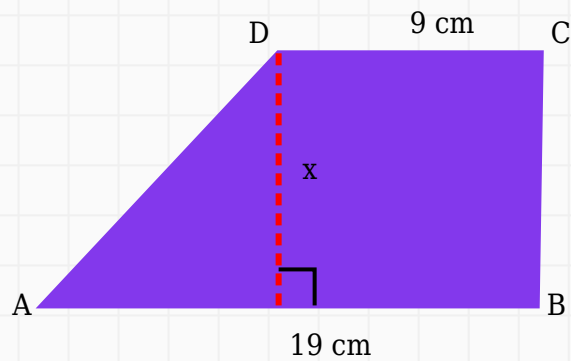

**Solution:**

**Formula: Height =  $(2 \times \text{Area}) \div \text{Sum of parallel sides}$**

$$\text{Height} = (2 \times 112) \div (9 + 19)$$

$$\text{Height} = 224 \div 28$$

$$\text{Height} = 8 \text{ cm}$$

**Answer:** 8 cm

### Question 15

The area of a trapezium is  $90 \text{ cm}^2$ . One parallel side is 24 cm and height is 5 cm. Find the other parallel side.

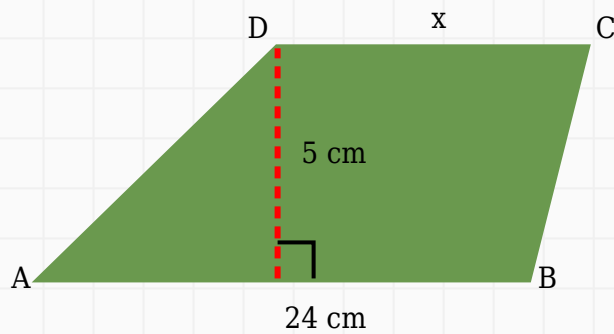

**Solution:**

**Formula: Area = Height  $\times$  (a + b)  $\div$  2**

$$90 = 5 \times (x + 24) \div 2$$

$$180 = 5 \times (x + 24)$$

$$36 = x + 24$$

$$x = 12 \text{ cm}$$

**Answer:** 12 cm

### Question 16

The area of a trapezium is  $214.5 \text{ cm}^2$ . Its parallel sides are 10 cm and 29 cm. Find the height.

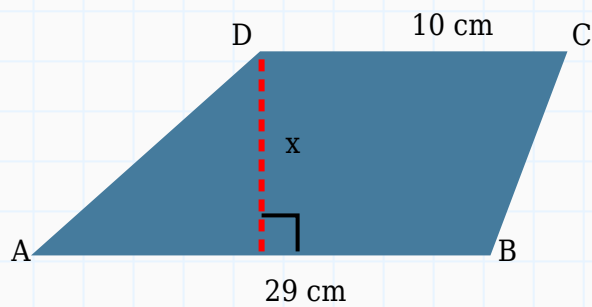

**Solution:**

**Formula: Height =  $(2 \times \text{Area}) \div \text{Sum of parallel sides}$**

$$\text{Height} = (2 \times 214.5) \div (10 + 29)$$

$$\text{Height} = 429 \div 39$$

$$\text{Height} = 11 \text{ cm}$$

**Answer:** 11 cm

### Question 17

Find the area of the trapezium having parallel sides 8 cm and 27 cm with height 9 cm.

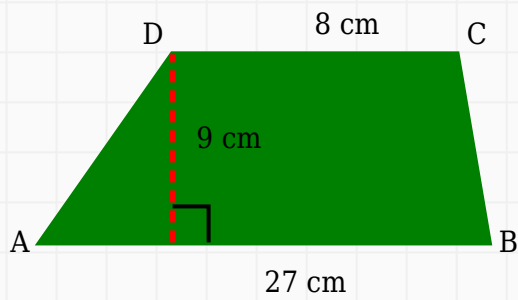

**Solution:**

**Formula:**  $\text{Area} = \text{Height} \times (\text{Sum of parallel sides}) \div 2$

$$\text{Area} = 9 \times (8 + 27) \div 2$$

$$\text{Area} = 9 \times 35 \div 2$$

$$\text{Area} = 157.5 \text{ cm}^2$$

**Answer:**  $157.5 \text{ cm}^2$

### Question 18

Find the area of the trapezium having parallel sides 8 cm and 26 cm with height 9 cm.

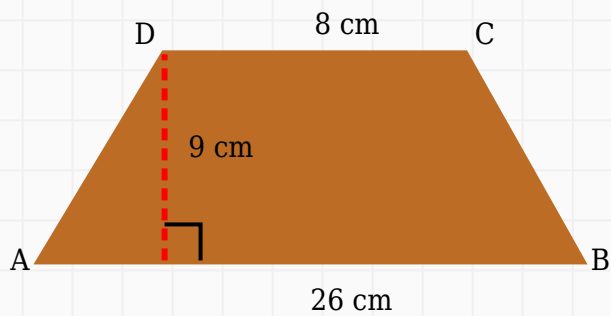

**Solution:**

**Formula: Area = Height  $\times$  (Sum of parallel sides)  $\div$  2**

$$\text{Area} = 9 \times (8 + 26) \div 2$$

$$\text{Area} = 9 \times 34 \div 2$$

$$\text{Area} = 153 \text{ cm}^2$$

**Answer:** 153 cm<sup>2</sup>

### Question 19

The area of a trapezium is 133 m<sup>2</sup>. One parallel side is 27 m and height is 7 m. Find the other parallel side.

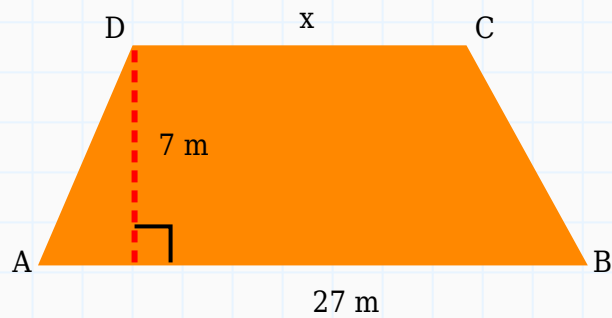

**Solution:**

**Formula: Area = Height  $\times$  (a + b)  $\div$  2**

$$133 = 7 \times (x + 27) \div 2$$

$$266 = 7 \times (x + 27)$$

$$38 = x + 27$$

$$x = 11 \text{ m}$$

**Answer:** 11 m

### Question 20

The area of a trapezium is  $99 \text{ cm}^2$ . One parallel side is 18 cm and height is 6 cm. Find the other parallel side.

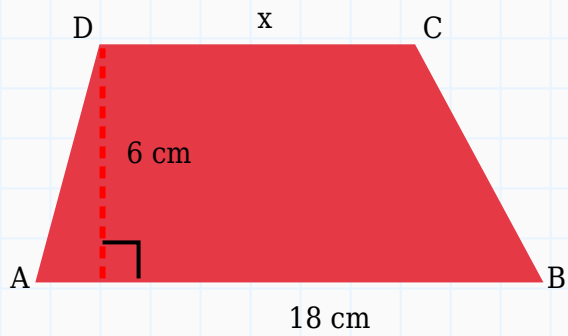

**Solution:**

**Formula:**  $\text{Area} = \text{Height} \times (a + b) \div 2$

$$99 = 6 \times (x + 18) \div 2$$

$$198 = 6 \times (x + 18)$$

$$33 = x + 18$$

$$x = 15 \text{ cm}$$

**Answer:** 15 cm